

**lr.products)**

LR CONVERTING PERIPHERAL PRODUCTS, SL

**AUTOMATIC SOLVENTLESS  
ADHESIVE MIXER  
AND METERING  
UNIT FOR LAMINATION**

- Accurate and reliable
- Production control
- Automatic g/m<sup>2</sup> calculations
- "On the fly" ratio changes
- Production data reports
- Maintenance trouble-free
- Several automatic refilling options



**lr.products)**

[www.lrproducts.net](http://www.lrproducts.net)

Poligono Pont Xetmar  
Calle F #28 ES17844 Cornellà de Terri  
Girona - Spain

T +34 972 59 64 35 / F +34 972 59 44 68  
info@lrproducts.net

**LR PERIPHERAL  
CONVERTING PRODUCTS**

- Ink viscosity controls
- Automatic ink pH regulation
- Ink temperature control
- Solventless mixers
- Monocomponent metering
- Solvent based mixers
- Automatic flexo wash-up units

**bi-2 mixer**

SOLVENTLESS ADHESIVES MIXING EQUIPMENT

**CNC gear pumping technology**  
More than 400 units installed world-wide



## CONTROL AND ACCURACY IN MIXING MAXIMUM RELIABILITY

### BI-2 MIXER

The Bi-2 Mixer is the most advanced technical solution for solventless adhesive mixing and metering, enabling the highest level of accuracy and quality for the lamination process.

This is achieved by means of the proven **(r.products)** gear pumping technology, controlled by an industrial electronic PLC platform and a proprietary developed software.

### AUTOFILL: OPTIONAL AUTOMATIC REFILLING

Increase productivity, no need to refill the mixer by hand, fully automates a previously tedious process.

It prevents the creation of a jelly skin on top of the adhesive as there is not any longer moisture coming inside. The auto-fill works on a complete closed way.

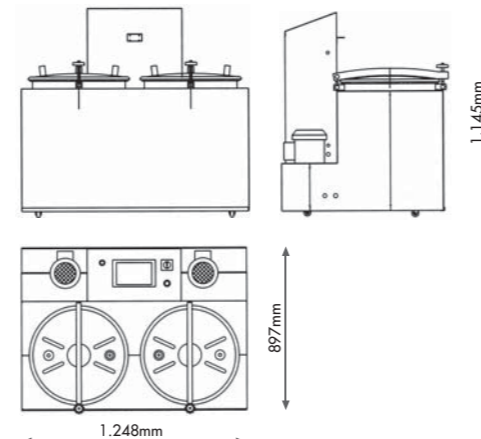

### BI-2 MIXER automatic refilling



#### AUTOFILL GRAV

- Automatic refilling by means of 2 additional valves
- Adhesive flows by means of gravity
- It works better with 1.000 kg adhesive containers
- Adhesive containers need to be placed on top of the mixer



#### AUTOFILL NEUMAT

- Automatic refilling by means of 2 additional pneumatic pumps
- Works better for 200 kg adhesive drums
- It allows the use of the drums on a vertical position
- No manipulation needed



#### AUTOFILL PUMP

- Automatic refilling by means of additional transfer gear pumps
- Remote refilling allowed, distance up to 50 meters aprox.
- Allows fully automatic refilling for several laminators
- Custom made solutions available

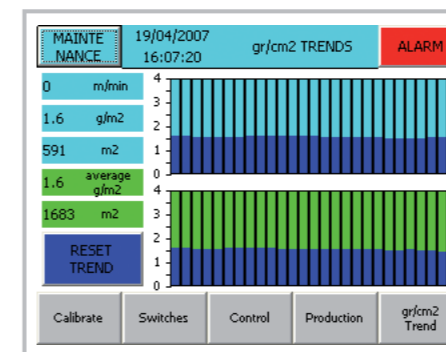
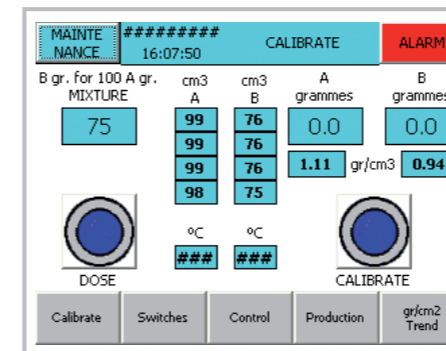

## OUTSTANDING FEATURES

### 1 Unique in the market: calibration function

- The calibration function allows the system to calibrate as a function of the adhesive.
- Once done, the unit accurately meters the exact amount of each component in weight ratio.

### 2 In line g/m<sup>2</sup> calculation function

- Once calibrated, the PLC makes a continuous calculation for the g/m<sup>2</sup>.
- A graphic display shows the operator any movement away from the desired amount.

### INCLUDED FEATURES

- High accuracy, easy to use and even easier to install
- MAN/AUTO, 'clean' and 'empty tanks' function
- Variable flow according to consumption
- Alarms and troubleshooting diagnostics
- Reports on consumption, output and g/m<sup>2</sup> coating
- Optimum temperature of adhesive maintained prior to production
- Can be installed in any laminator available in the market
- Totally problem free maintenance
- Independent temperature selection
- Double temperature control for higher security
- Permanent level control by means of ultrasonic sensors
- Stainless steel construction

### USER FRIENDLY EQUIPMENT

- Interchangeable static mixer on the mixing head
- Adhesive mixing and application just at the metering point
- Easy to install at set-up
- Stainless steel removable tanks
- Tool free, easy to clean and manipulate

### Blocking valve as an optional



- Blocking valve for mixing thick adhesives.
- Recommended when using very thick adhesives, or adhesive systems with a very big difference in both component viscosities.
- It will prevent drop leaks from the mixer on the laminator.
- Independant blocking system for the 2 components.